

Pillar Type Dry Barrel Fire Hydrants

## Above ground hydrant DN 80/100

from Series MF – H/01

### Brochure



# Mundus Foundation

Publication 2012

## **Products and prices**

The catalogue is for information only and is not legally binding. It conveys details on standard delivery program. Further pumps, valves and fittings, drive, equipments and control systems or accessories may be specially developed on request and can be provided according to a customer's wishes on the basis of a contract agreement.

Please obtain the latest prices by contacting authorized representative.

This details mentioned in the documentation are listed as exactly as possible. A guarantee, however, for absolute correctness is not undertaken. Constructive modifications according to the technical development rights of our products are reserved.

## **Validity**

Illustrations and drawings, either direct or copied may however be used without express consent.

# Mundus Foundation

## **Pillar Type Dry Barrel Fire Hydrants**

### **1. Introduction**

In firefighting, a primary role is that extinguishing equipments should be visible and accessible. Thus, above ground dry barrel fire hydrant is a good solution against the invisibility disadvantage of underground fire hydrants.

This is true that a fire develops depending on nature and characteristics of the plant or building subject to fire, however, the important thing is duration of attempting to extinguishing fire, which has to be the shortest possible. Above ground dry barrel hydrants made is possible.

### **2. Applications**

In factories, storages, industrial plants, buildings, forest areas, accommodations, which are susceptible to fire, above ground fire hydrants allow to extinguish fire quickly as well as offering another as water supply to the fire brigade.

# Mundus Foundation

## 3. Technical Data

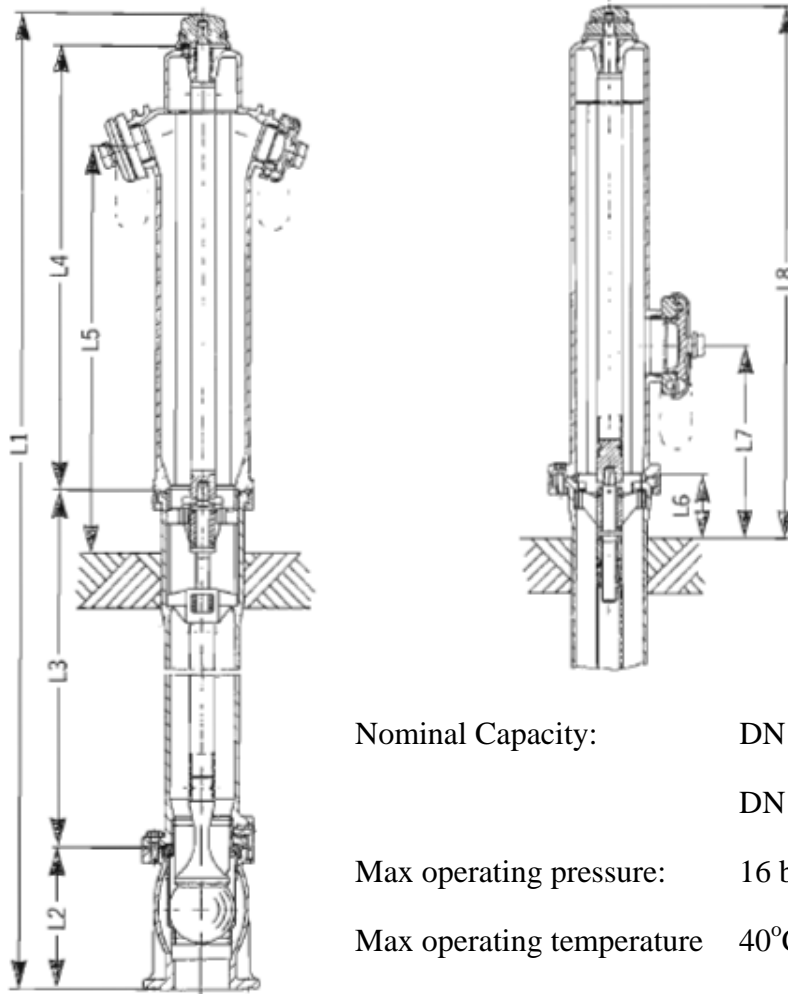

Nominal Capacity: DN 80 – 179.9 m<sup>3</sup>/hr

DN 100 – 252.2 m<sup>3</sup>/hr

Max operating pressure: 16 bar

Max operating temperature 40°C

DN	Outlet diameters (Coupling)	Cover depth (mm)	Dimensions (mm)								Weights (Kg)
			L1	L2	L3	L4	L5	L6	L7	L8	
80	2"	1000	1885		770						80
		1250	2135	220	1020	835	800	135		1030	85
		1500	2385		1270						90
100	2 ½"	1000	1885		725						102
		1250	2135	265	975	835	790	135	385	1030	109
		1500	2385		1225						116

# Mundus Foundation

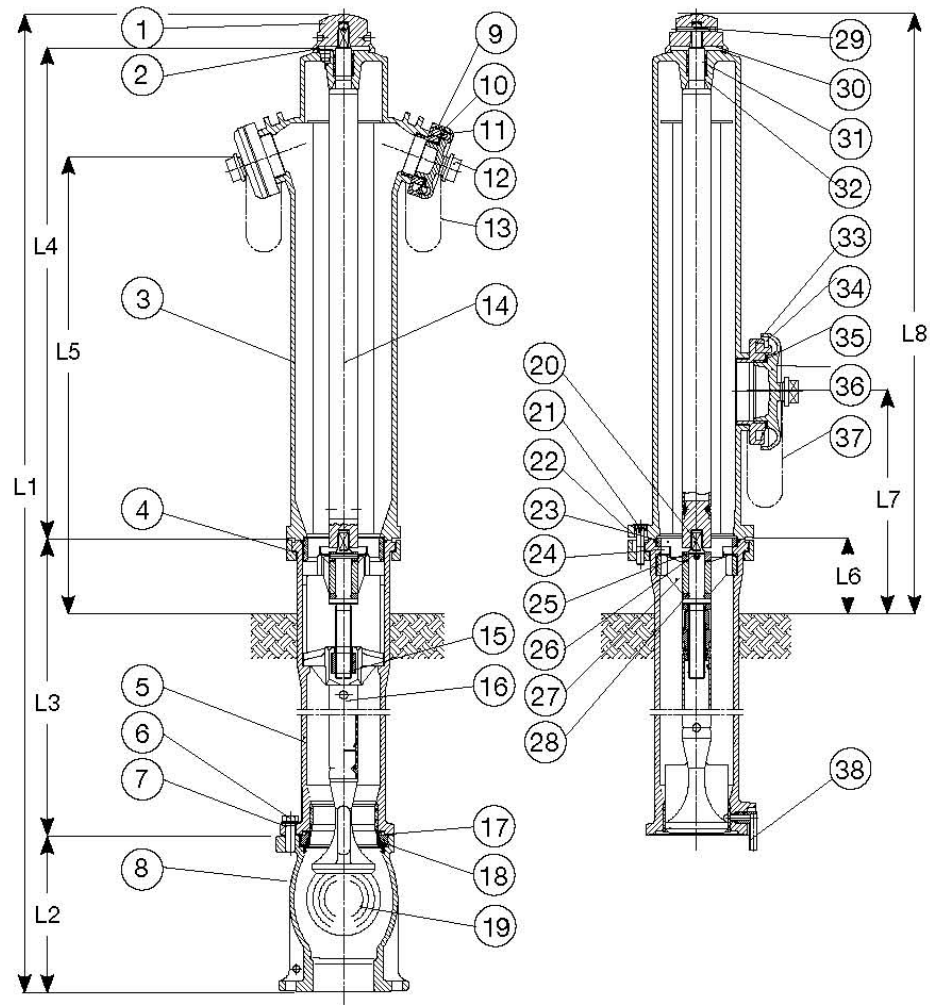

## 4. Components List

1 Confirmation head	11 Gasket B	21 Titanium socket	31 Wipers
2 Ventilation valve	12 Deck capsule B	22 Allen screw	32 O – ring
3 Casing pipe, top	13 Chain	23 O – ring	33 O – ring (DIN 100)
4 Terminal half	14 Linkage top	24 Blocking ring	34 Rigid coupling A (DN 100)
5 Casing pipe, down	15 Spindle nut	25 Ring	35 Gasket A (DN 100)
6 Hexagonal screw	16 Linkage base	26 Dowel pin	36 Capsule coverage A (DN 100)
7 Disc	17 Flat gasket	27 Spindle guide	37 Chain (DN 100)
8 Ball housing	18 Seal for half barrier	28 Disc below	38 Drain nipple
9 O – ring	19 Ball	29 Dowel pin	
10 Fixed coupling B	20 Valve spindle	30 Disc	

# Mundus Foundation

## 5. Technical description

Above ground hydrants

- Flange PN 10/16 to DIN 2501

- Couplings, Deck caps Al

- Housing EN-GJS-400-15

Inside enamel to DIN 3475

Outside additional EKB coating to DIN 30677 Part 2

Red, other colors on request

- Spindle, screws and nuts from stainless steel

- Spindle nut Brass

- O – ring NBR

- Gasket Rubber

# Mundus Foundation

Your Contact

--